

Product Data

Artificial Mastoid — Type 4930

USES:

- Objective measurement of hearing aid and audiometer bone vibrator parameters
- Frequency response and output determination of bone vibrators
- Design and production testing and calibration of vibrators

FEATURES:

- Stable, reproducible simulation of the mechanical characteristics of the human head
- Built-in force transducer with high-stability characteristic
- Calibrator provides for checking and calibration of all parameters
- Adjustable static force from 2N to 8N
- 50Hz to 10kHz frequency range
- Meets IECR 373, BS 4009 (1975), and ANSIS3.26-1981

The Artificial Mastoid Type 4930 has been designed for the calibration of bone conduction hearing aids and bone vibrators used in audiometry. It consists of a mechanical simulation of the human head, incorporating a built-in force transducer to monitor the output of the device to be calibrated. All the components of the Artificial Mastoid have been selected to ensure both excellent long-term stability and accurate correspondence with the mechanical characteristics of the human mastoid. It is designed in accordance with the International Electrotechnical Commission publication IECR 373 (1971) including revision, and meets the requirements of the British Standard BS 4009 (1975) and American National Standard ANSIS3.26-1981.

The Artificial Mastoid consists of an inertial mass, simulating the human head, mounted on a base-plate by resilient plastic spacers which surround the securing-bolts. The base-plate is carried on a suspension composed of three conical springs filled with foam rubber to provide damping. The natural frequencies of this suspension, which isolates the whole apparatus from external disturbanc-

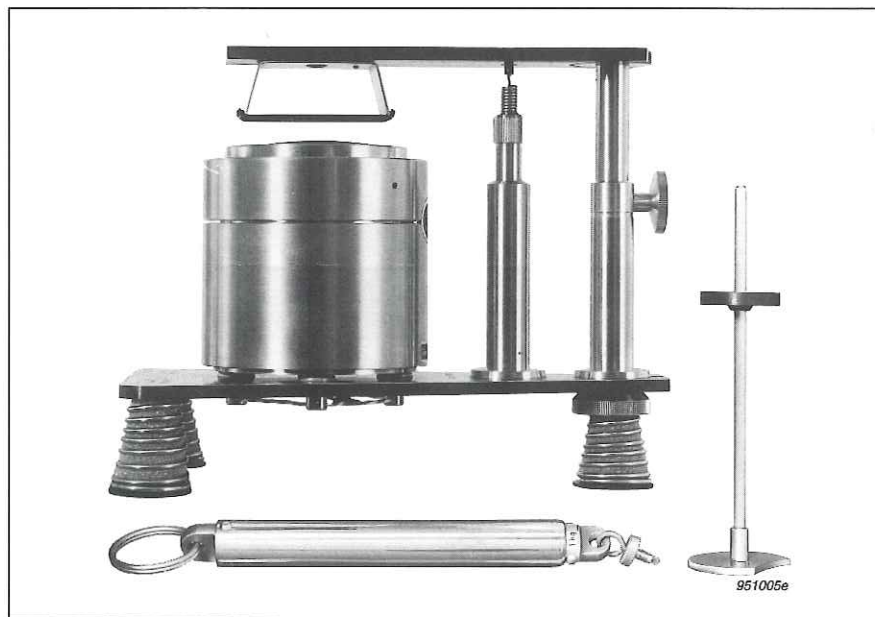

es such as someone bumping the table during use, are all below 5 Hz, which is one-tenth of the low-frequency limit of the working range.

The base-plate also carries a loading-arm and its associated supports. The function of this is to maintain the device to be calibrated reliably in position, pressing against the calibra-

tion surface of the Artificial Mastoid with a static force which can be adjusted between 2 and 8 N. A spring balance and level indicator are included to facilitate this adjustment. Rubber retaining-bands ensure virtually massless rear support for the device under calibration.

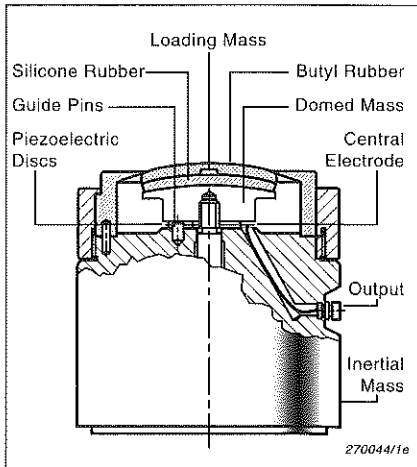

Fig. 1 Cross-sectional drawing showing the key features of the Artificial Mastoid

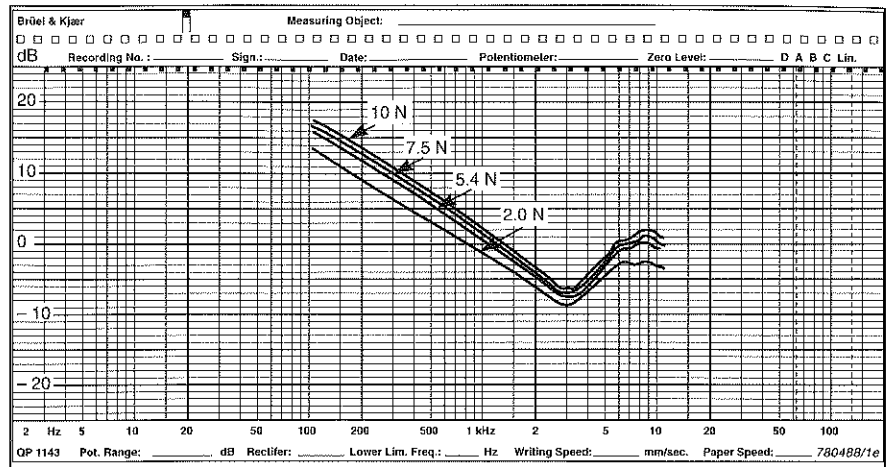

Fig. 2 Typical mechanical impedance characteristic for Artificial Mastoid, showing the effect of changing static load

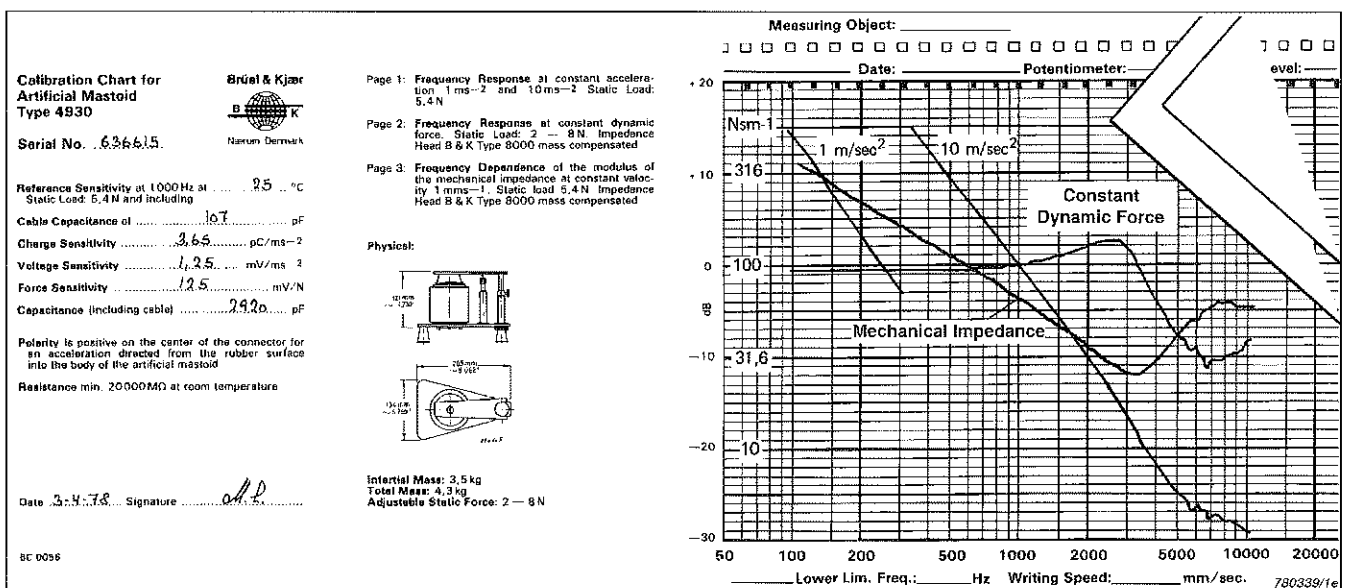

Fig. 3 Typical individual calibration chart as delivered with the Artificial Mastoid showing three calibration curves superimposed on each other

The inertial mass is shown in cross-section in Fig. 1. It weighs 3,5 kg, is machined from brass and is nickel-plated. Above this is a smaller, domed mass made of stainless steel. The two are connected by a high-strength steel bolt, which pre-loads the piezoelectric discs forming the force transducer. These discs are of lead zirconate titanate, and are artificially aged for long-term stability. A teflon pin passes through the centre of each disc and is anchored in the inertial mass. An electrode connected to the discs carries the signal to the output socket, which is a standard miniature coaxial socket with a UNF 10-32 external thread, suitable

for mating with Brüel & Kjær connecting cable AO 0038.

The domed mass is covered by a neoprene-rubber pad and a butyl-rubber pad, the latter incorporating a loading-mass. These items are all vulcanised together to form an integral unit. This method of construction permits good product repeatability, and simulates the complex impedance of the skin within the specified frequency range as closely as possible (Fig. 2).

When the electrical output of the Artificial Mastoid is connected to suitable instrumentation, such as a sound level meter or vibration-meas-

uring system, the complete characteristics of bone vibration may be reproducibly determined. The instrumentation output will be proportional to the force variable, but if it is required to determine the acceleration characteristic of the bone vibrator, this may be readily calculated by using the calibration chart. Each Artificial Mastoid is calibrated by Brüel & Kjær and supplied with a calibration chart including three plots showing mechanical impedance, output for constant force, and output for constant acceleration, all as functions of frequency (Fig. 3).

Automatic graphic recordings of frequency response curves may be made using, for example, the instruments illustrated in Fig.5, or the Brüel & Kjær Type 2118 Audio Test Station, which is an integrated response plotter designed primarily for audio-medical applications.

Calibration of the Artificial Mastoid

The special components needed for calibration by user of the Artificial Mastoid are available from Brüel & Kjær.

The following items are necessary for calibration:

- Artificial Mastoid Type 4930
- Impedance Head Type 8000
- Mini-Shaker Type 4810
- Shaker Arm UA0274
- Spring Arrangement UA0263

The Mini-Shaker is used to excite the Artificial Mastoid, via the Impedance Head, which provides electrical outputs of both force and acceleration. These items are secured in position against the calibration surface of the Artificial Mastoid by the Shaker Arm, and the static force is adjusted to any value between 2 and 8 N by means of the Spring Arrangement. With appropriate instrumentation, this apparatus enables measurements to be taken over the frequency range specified of force, acceleration, velocity and displacement, keeping any one of these quantities constant, and thereby to determine, and calibrate for, mechanical impedance.

The Mini-Shaker, Impedance Head and similar associated instrumentation may also be used to take the same measurements on human mastoids and foreheads, and to determine bone conduction threshold values.

The Type 3505 is useful where it is most convenient to calibrate a complete system, i.e. Artificial Mastoid and associated instrumentation, instead of calibrating the instrumentation separately and then making allowances for the characteristics of the Artificial Mastoid. It is also an advantage for the user to be able to check that the Artificial Mastoid has not become damaged in use.

Electrical connections to both the Mini-Shaker and the Impedance Head are made by means of the same kind of miniature 10-32UNF screw-locking coaxial connector as used on the Artificial Mastoid.

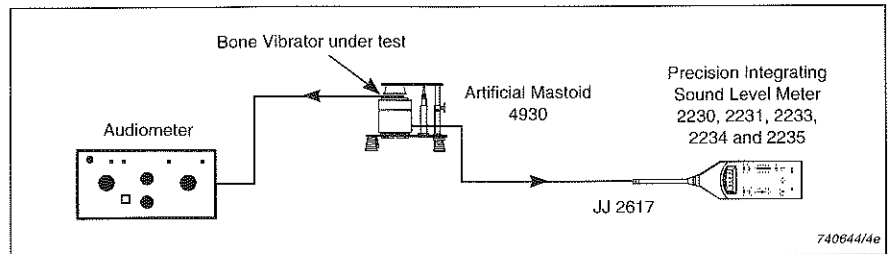

Fig.4 Basic arrangement for calibrating bone vibrators with the Artificial Mastoid

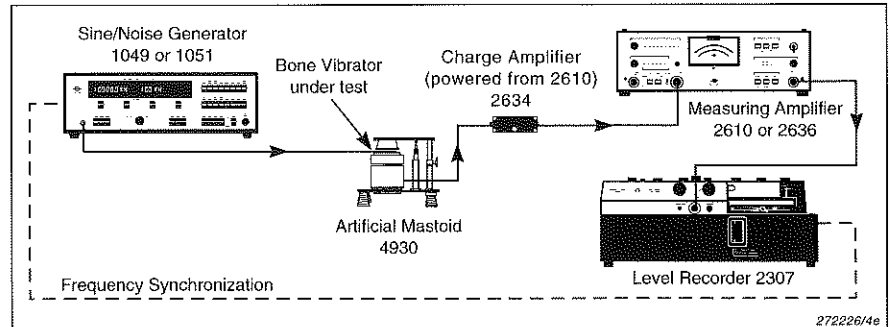

Fig.5 Arrangement of equipment for plotting automatic frequency response graphs of bone vibrators

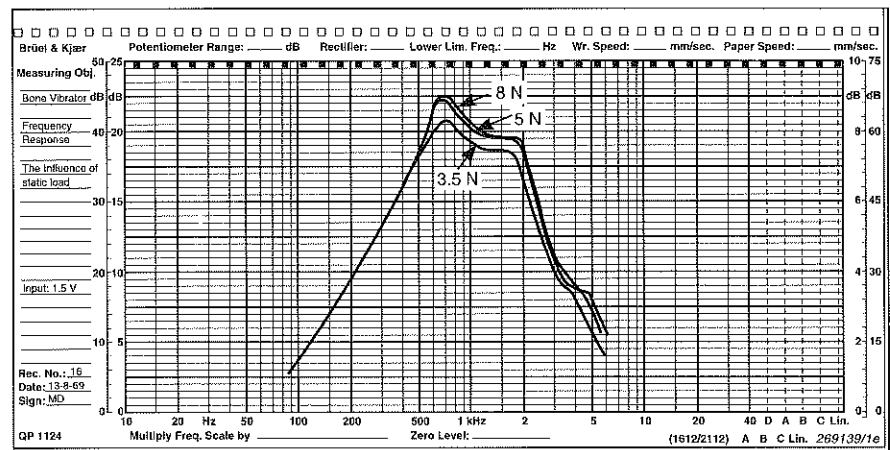

Fig.6 Example of a frequency response graph obtained with an equipment arrangement similar to Fig.5

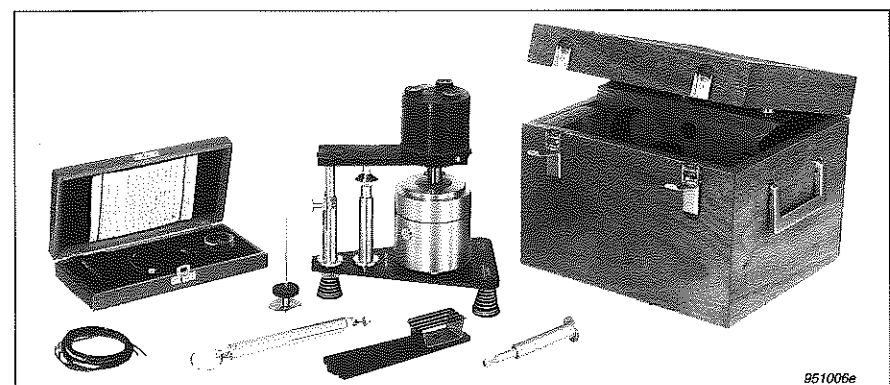

Fig.7 Artificial Mastoid with calibration set-up

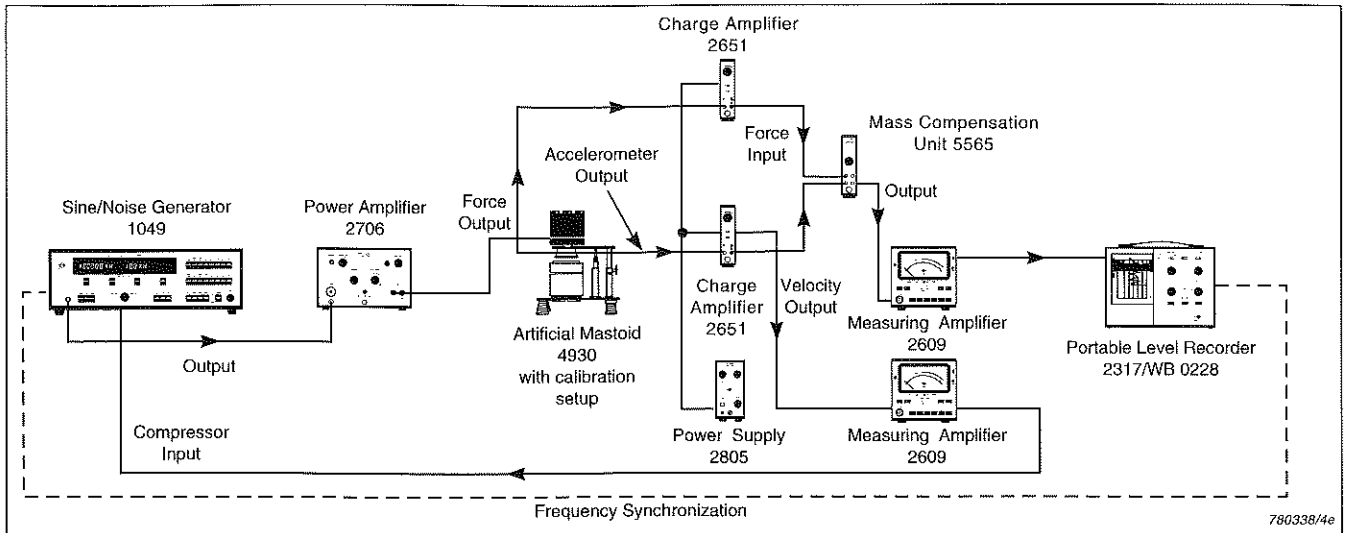

Fig.8 Arrangement for plotting the mechanical impedance of the Artificial Mastoid against frequency, using the calibration set-up

Specifications 4930 and 3505

<p>ARTIFICIAL MASTOID TYPE 4930</p> <p>Frequency Range: 50 Hz to 10 kHz</p> <p>Charge Sensitivity to Acceleration: 2 pC per ms² at 1.0 kHz</p> <p>Voltage Sensitivity to Acceleration: -63 dB ref. 1 Volt per ms² (0.7 mV per ms²) at 1.0 kHz</p> <p>Charge Sensitivity to Force: 300 pC/N</p> <p>Voltage Sensitivity to Force: 100 mV</p> <p>Capacitance: 3 nF</p> <p>Adjustable Satic Force: 2 to 8 N</p> <p>Calibration Surface Area: 1260 mm²</p> <p>Inertial Masa: 3.5 kg (7.7 lb)</p> <p>Dimensions: Height: 165 mm (6.5 in) (maximum) Width: 205 mm (8.1 in) Depth: 134 mm (5.3 in)</p> <p>Weight: 3.4 kg (9.5 lb)</p> <p>IMPEDANCE HEAD TYPE 8000**</p> <p>Contact Area: Plane circular 175 mm²</p> <p>* Individually calibrated ** For full specifications, ask for separate Product Data for these items</p>	<p>Accelerometer Charge Sensitivity: 3 pC per ms²</p> <p>Accelerometer Voltage Sensitivity: 3 mV per ms²</p> <p>Force Gauge Charge Sensitivity: 370 pC per N</p> <p>Force Gauge Voltage Sensitivity: 370 mV per N</p> <p>Effective Mass below Force Gauge: 1.3 g (0.046 oz)</p> <p>Capacitance of Transducer Elements: 1 nF (each)</p> <p>Frequency Range: 1 Hz to 10 kHz</p> <p>Total Weight: 29 g (1.02 oz)</p> <p>COMPLIANCE WITH STANDARDS:</p> <table border="1"> <tr> <td style="text-align: center;">CE</td> <td>CE-mark indicates compliance with: EMC Directive.</td> </tr> <tr> <td>EMC Emission</td> <td>EN 50081-1 (1992): Generic emission standard. Part 1: Residential, commercial and light industry. CISPR22 (1993): Limits and methods of radio disturbance characteristics of information technology equipment. Class B Limits. FCC Class B limits.</td> </tr> <tr> <td>EMC Immunity</td> <td>EN 50082-1 (1992): Generic immunity standard. Part 1: Residential, commercial and light industry. Note: The above is guaranteed using accessories listed in this Product Data sheet only.</td> </tr> </table>	CE	CE-mark indicates compliance with: EMC Directive.	EMC Emission	EN 50081-1 (1992): Generic emission standard. Part 1: Residential, commercial and light industry. CISPR22 (1993): Limits and methods of radio disturbance characteristics of information technology equipment. Class B Limits. FCC Class B limits.	EMC Immunity	EN 50082-1 (1992): Generic immunity standard. Part 1: Residential, commercial and light industry. Note: The above is guaranteed using accessories listed in this Product Data sheet only.	<p>MINI-SHAKER TYPE 4810**</p> <p>Frequency Range: 10 Hz to 10 kHz</p> <p>Force Rating: 10 N pk (65 Hz to 4 kHz) 7 N pk (4 kHz to 18 kHz)</p> <p>Mass of moving System: 18 g (0.64 oz)</p> <p>Dimensions: Diameter: 76 mm (3.0 in) Height: 79 mm (3.1 in)</p> <p>Weight: 1.4 kg (3.1 lb)</p> <p>Electrical Impedance: 3.5 Ω at 500 Hz</p>
CE	CE-mark indicates compliance with: EMC Directive.							
EMC Emission	EN 50081-1 (1992): Generic emission standard. Part 1: Residential, commercial and light industry. CISPR22 (1993): Limits and methods of radio disturbance characteristics of information technology equipment. Class B Limits. FCC Class B limits.							
EMC Immunity	EN 50082-1 (1992): Generic immunity standard. Part 1: Residential, commercial and light industry. Note: The above is guaranteed using accessories listed in this Product Data sheet only.							

Ordering Information

<p>Type 4930 Artificial Mastoid</p> <p>Accessories Included: UA 0247 Spring balance 1 kg UA 0262 Level Indicator QH 0006 Slide rule w. case Calibration Chart</p>	<p>Coaxial Cable Adapter, UNF to Bruel & Kjaer Standard</p> <p>Type 3505 Artificial Mastoid with Calibrator Including: Type 4930 Artificial Mastoid</p>	<p>Type 8000 Impedance Head Type 4810 Mini-Shaker UA 0274 Shaker Arm UA 0263 Spring Arrangement</p>
---	---	---

Brüel&Kjær reserves the right to change specifications and accessories without notice



Part N.: BP-0266---



Descript.: Artificial Mastoid - Type 4930

Qty.: **1 Pcs**

Loc.: 0101.1.DK LITT

Del. N.: **1134838**

Ship to: Italy

Trans. N.: 1515519

Ship date: 15-MAY-2006

Page/Id: 1 / 25

Brüel & Kjær 

WORLD HEADQUARTERS: DK-2850 Nærum · Denmark · Telephone: +45 42 80 05 00 · Telex: 37316 bruk dk · Fax: +45 42 80 14 05

Australia (02) 450-2066 · Austria 00 43-1-865 74 00 · Belgium 016/44 92 25 · Brazil (011) 246-8166 · Canada: East (514) 695-8225 West (604) 591-9300 · China 10-8419625
Czech Republic 02-67 021100 · Finland 90-229 3021 · France (1) 64 57 2010 · Germany 06151/8149-0 · Great Britain (0181) 954-2366 · Holland (0)30 6039994
Hong Kong 2548 7486 · Hungary (1) 215 83 05 · Italy (02) 57 60 4141 · Japan 03-5420-7302 · Republic of Korea (02) 554-0605 · Norway 66 90 44 10 · Poland (0-22) 40 93 92
Portugal (1) 471 14 53 · Singapore 735 8933 · Slovak Republic 07-37 61 81 · Spain (91) 368 10 00 · Sweden (08) 711 27 30 · Switzerland 01/940 09 09
Taiwan (02) 713 9303 · Tunisia (01) 750 400 · USA (800) 332-2040
Local representatives and service organisations worldwide

BP 0266-16

PRINTED IN DENMARK BY NÆRUM OFFSET

95/12